

1 CI90
1 CI90N
1 CI120
1 CI120N
1 CI150
1 CI150N
1 CIA180

Manuale d'istruzioni
Instruction manual

Complimenti per aver acquistato una apparecchiatura Barazza!

Questa è un'apparecchiatura di grande qualità in grado di accompagnarvi nel Vostro lavoro per lungo tempo in modo affidabile e sicuro fornendo prestazioni di altissimo livello.

L'installazione e l'uso dell'apparecchiatura è semplice e immediato.

Vi invitiamo a leggere attentamente questo manuale: ciò permetterà un'installazione e un utilizzo corretto che manterrà la Vostra apparecchiatura sempre perfetta ed efficiente negli anni.

Per agevolare la lettura del manuale sono riportati i seguenti simboli:

Congratulations on purchasing a Barazza appliance!

This safe and reliable high-quality appliance can assist you in your work with long-lasting top-level performance.

It also has the added advantage of being quick and simple to install and easy to use.

Please read this manual carefully, as it provides important information for the correct installation and use of the appliance which will ensure its long-term efficiency.

The following symbols are used to assist you in reading this manual:



Prescrizioni importanti per la sicurezza personale e dell'apparecchiatura



Important rules for personal safety and the safety of the appliance



Informazioni generali



General information



Il Costruttore si riserva di apportare ai propri prodotti e a questo manuale le modifiche che riterrà opportune senza obbligo di preavviso.
I disegni, gli schemi di installazione e le tabelle contenuti all'interno del manuale sono da ritenersi indicativi ed esclusivamente a titolo d'informazione.



The manufacturer reserves the right to make any changes deemed suitable to the product without prior notice. The drawings, installation diagrams and tables contained in this manual are approximate and for informational purposes only.

INCASSO APPARECCHIATURA

BUILT-IN INSTALLATION



Accertarsi del perfetto stato e della stabilità del mobile nel quale saranno incassate le apparecchiature (Normativa DIN 68930).



Make certain that the cabinet in which you will be installing the appliance is in perfect condition and completely stable (Standard DIN 68930).



Nelle realizzazioni fuoriserie, le dimensioni di ingombro sono "personalizzate".



With custom made models, dimensions are made-to-order.

Preparare un foro di incasso con le misure indicate in figura:

Prepare an embedded hole with measurements as specified in figures:

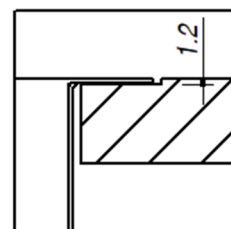
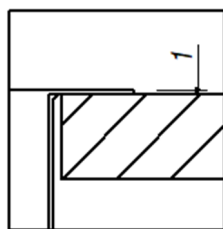

90

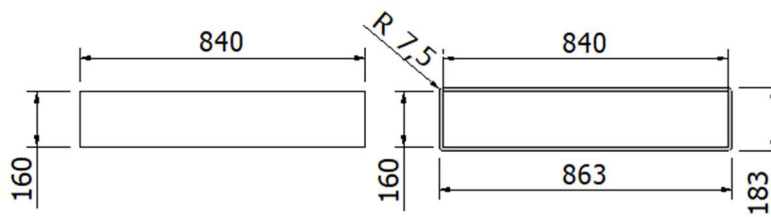

120

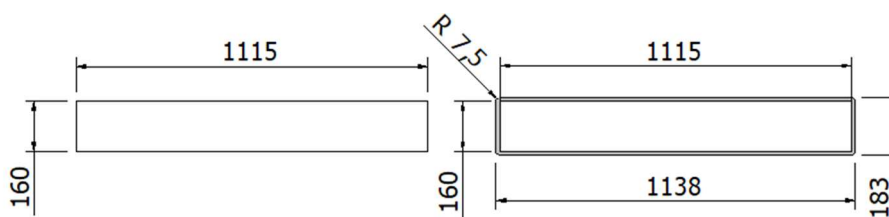

150

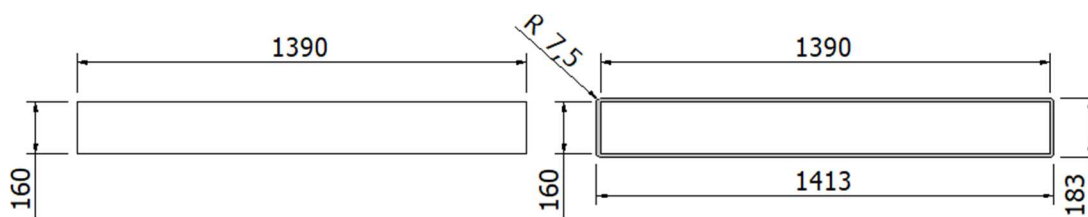

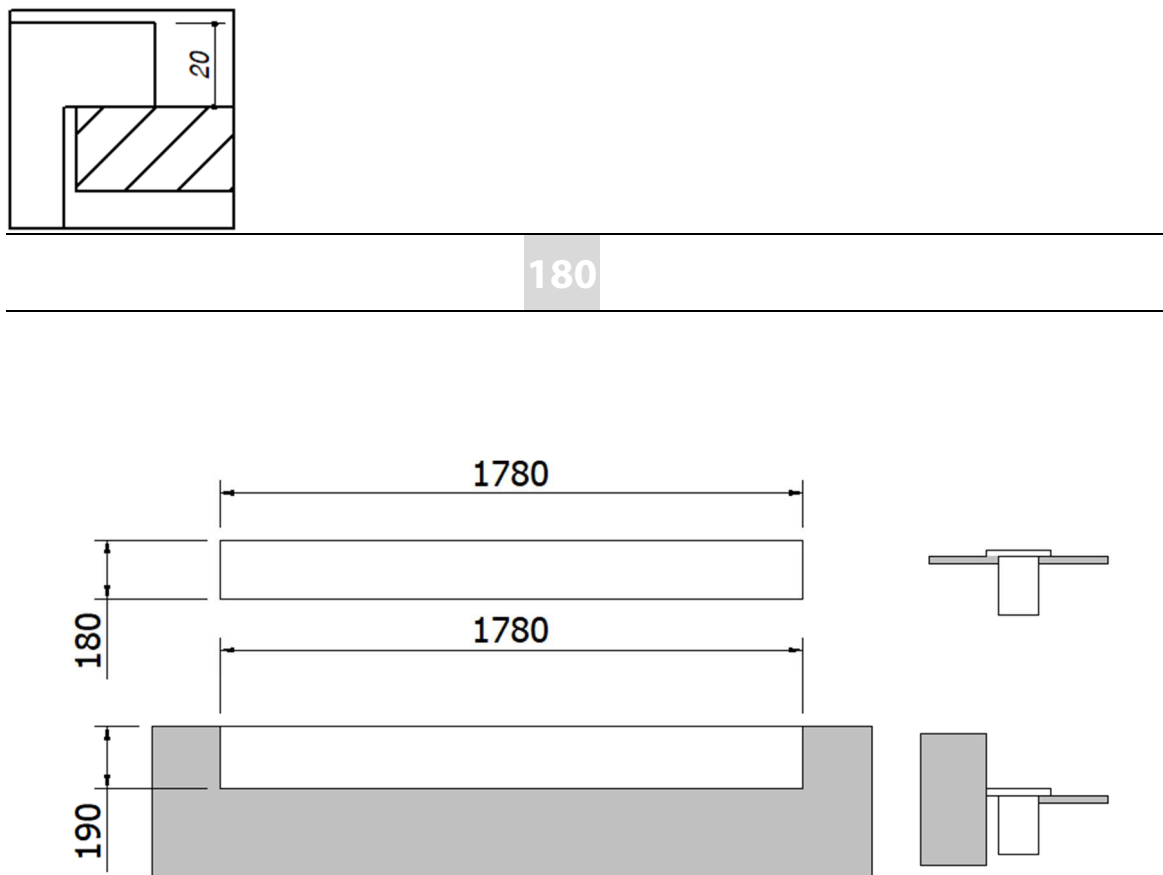

CANALI A FILO

Sistemare l'apparecchiatura sopra il foro d'incasso (fig. 2A part. 1) bloccandola con le viti e le staffe in dotazione (fig. 2A part. 2). Sigillare la fessura tra canale e abbassamento con silicone (fig. 2A part. 3) e pulire l'eccesso (fig. 2A part. 4).

CANALI AD INCASSO/APPOGGIO

Sistemare l'apparecchiatura sopra il foro di incasso spingendola contro il top (fig. 2B part. 1). Bloccare l'apparecchiatura con le viti e le staffe date in dotazione (fig. 2B part 2).

CANALI AD APPOGGIO A PARETE

Posizionare il profilo alla giusta altezza sulla parete per l'installazione del canale (fig. 2C part 1) e bloccarlo con viti di fissaggio (fig. 2C part 2)
Inserire l'apparecchiatura nel foro tra il piano e la parete (fig. 2D part. 1). Bloccare l'apparecchiatura con le viti e le staffe date in dotazione (fig. 2D part 2).

FLUSH CHANNELS

Arrange the appliance above the embedded hole (fig. 2A part.1) secure it using the screws and brackets provided (fig. 2A part. 2). Seal the gap between the channel and lowering with silicone (fig. 2A part. 3) and remove any excess (fig. 2A part. 4)

BUILT-IN CHANNELS

Arrange the appliance above the embedded hole (fig. 2B part. 1).
Secure the appliance using the screws and brackets Provided (fig. 2B part. 2)

WALL OVERBENCH CHANNELS

Position the profile at the right height on the wall for the installation of the channel (Fig. 2C part 1) and lock it with fixing screws (Fig. 2C part 2)
Insert the appliance in the hole between the top and the wall (fig. 2D part. 1).
Secure the appliance using the screws and brackets Provided (fig. 2D part. 2)

2
A

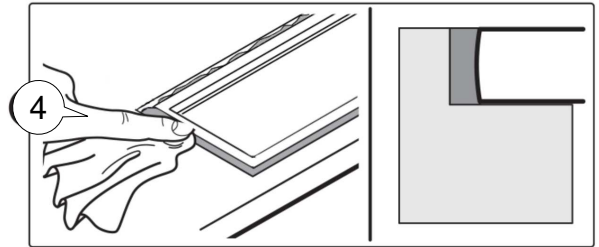
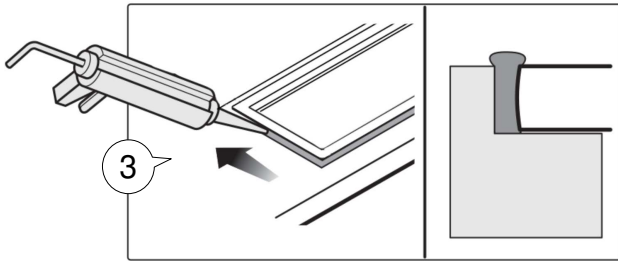
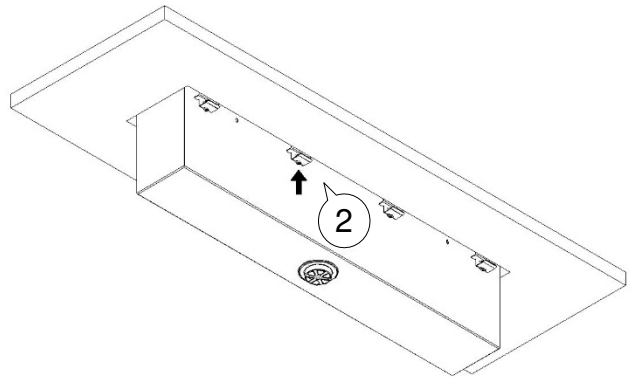
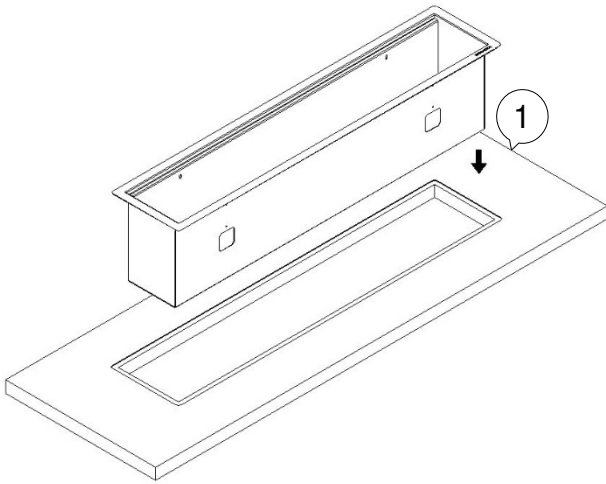

2B

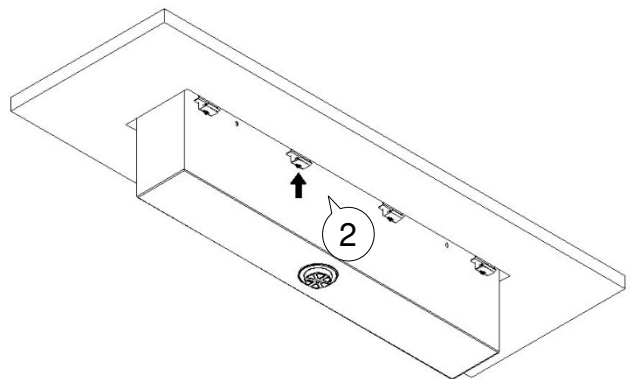
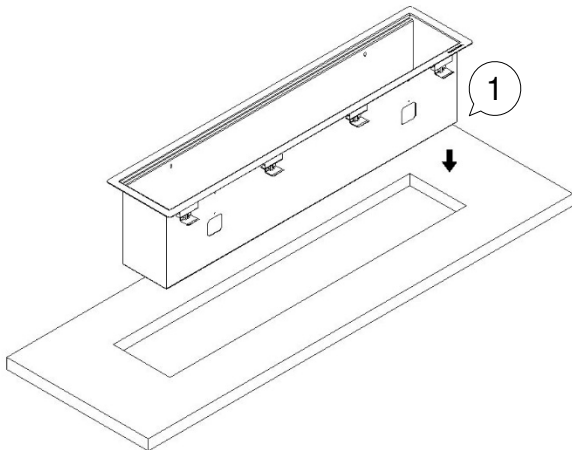

2C

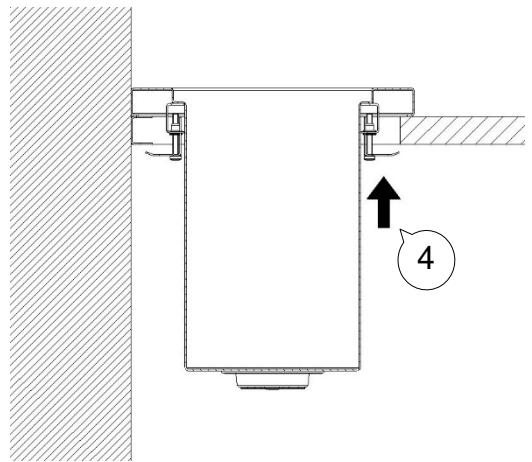
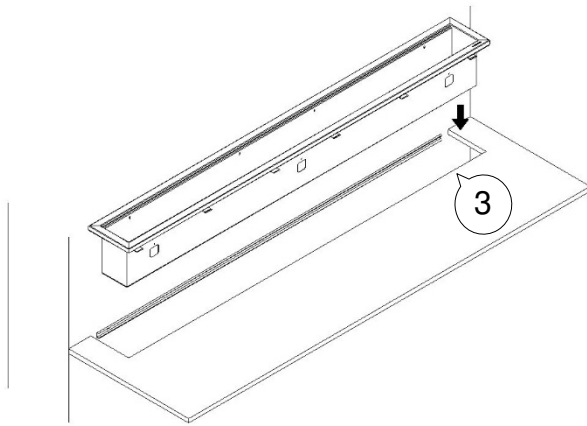
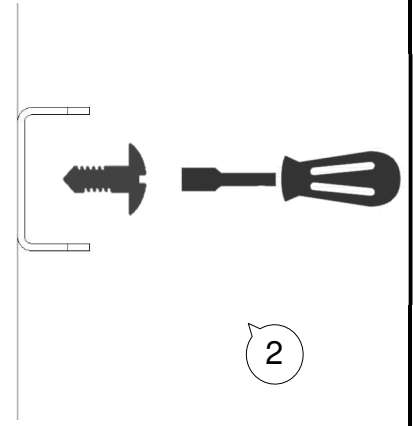
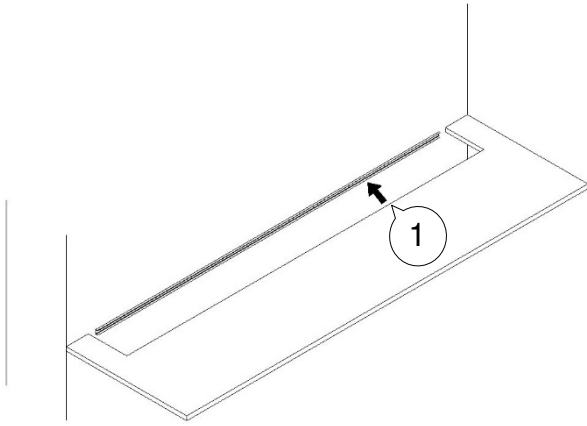

Nelle realizzazioni fuoriserie il sistema di fissaggio è personalizzato.



With custom made models, assembly is personalised.

INSTALLAZIONE ACCESSORI

ACCESSORIES INSTALLATION

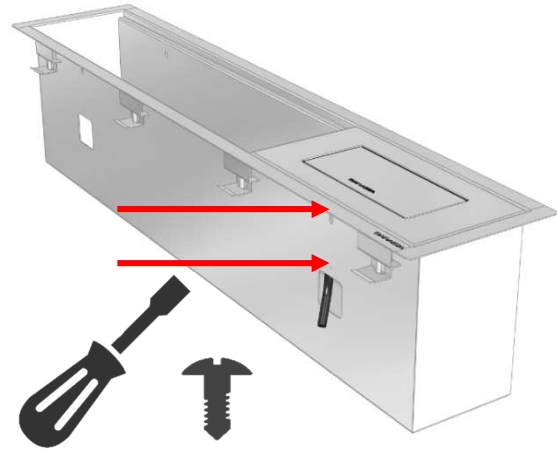

90 cm

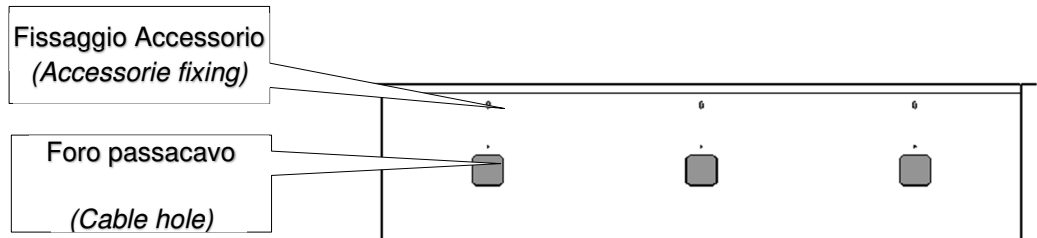

120 cm

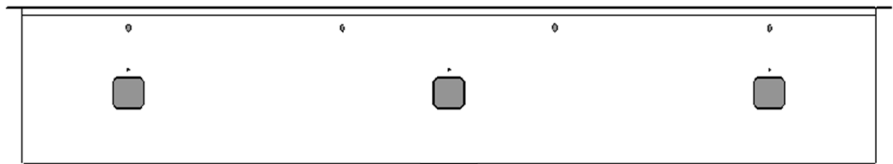

150 cm

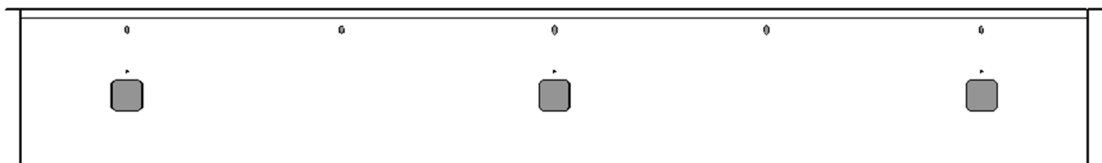

180 cm

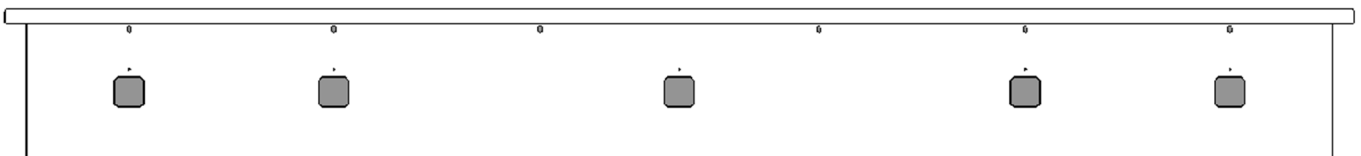

BARAZZA
taste of design



Barazza srl

31025 Sarano di S.Lucia di Piave
(TV) ITALIA – Via Risorgimento, 14

T +39 0438 62888 F +39 0438 64901
info@barazzasrl.it – barazzasrl.it