



Icon Exclusive built-in compact combi-steam oven

Touch Control + knobs

1FEVEVCN



Description

- 18 manual functions
- 30 automatic cooking programs
- Veggy mode
- maximum temperature: 250 °C
- progressive adjustment 35-100 °C in steam mode
- capacity: 40 litres
- Touch control multilingual digital programmer + knobs
- features: front controls, knobs and handle in Soft-Touch finish, Easy Clean oven interior, extractable and removable door with quadruple hinges, tangential cooling fan, internal light, side racks, 0.8 l water tank accessible during cooking
- equipment: 1 deep Easy Clean enamelled steel drip tray, 1 deep steel perforated drip tray, 1 steel rack, temperature probe
- safety devices: electronic child-safety lock
- maximum absorbed power: 3 kW

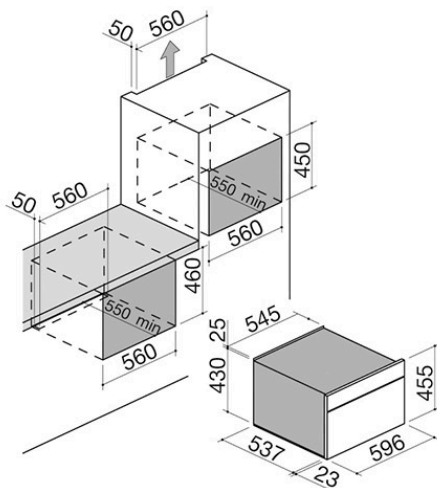

SEE OTHER AVAILABLE DESIGNS:



1FEVSVC



1FEVGVC



Plus

Detailed Features



Touch Control display

The high-definition Touch Control display offers precise, simple, and intuitive viewing of the various cooking and oven settings.



Automatic cooking programs ovens

Automatic cooking programs allow you to achieve perfect results simply by selecting the desired recipe and placing the food in a cold oven.



Child safety lock

Prevents accidental changes to the hob settings, particularly by children.

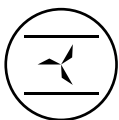

Convection functions

Multifunction electric oven with fan-assisted air circulation, distributing heat evenly for fast and uniform cooking.



Veggy mode

Designed for those who do not consume meat or fish, this mode excludes all automatic cooking programs based on animal proteins.



Soft-Touch finish elements



Elegant to the eye and pleasant to the touch, the Soft-Touch finish features on various product lines, covering knobs, handles and control panels.



Easy Clean oven interior

All Barazza ovens feature an Easy Clean interior, a surface treatment that facilitates and speeds up cleaning.



Soft-Close hinges

Soft-Close hinges are a mechanical device that slows down and cushions the final stage of door closing.

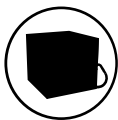

Cool door

Barazza oven doors, removable and dismountable, feature triple or quadruple glass with heat-reflective crystals that prevent the outer surface from overheating.



Steam

The steam function, adjustable by degree, allows healthy cooking while preserving organoleptic properties and nutrients.



Module height 45

The ovens and coordinated products are available in various heights to adapt perfectly to any installation and configuration need.



40-litre cavity capacity

The large cavities of Barazza ovens help reduce cooking times and energy consumption.

SISTEMA **FEEL**
Good



Temperature probe

The temperature probe communicates with the oven software to monitor the internal temperature of foods that require precise target values.



Energy rating A

All 60 and 90 cm ovens by Barazza belong to energy class A+: maximum efficiency to optimise performance and reduce energy consumption. Barazza operates according to an eco-sustainability principle, favouring future generations.



Functions

Main Functions



Top + bottom heating element

Suitable for any type of dish, but particularly effective for baking cakes, pizzas and soufflés, and for roasting.



Bottom heating element

Suitable for baking biscuits, tarts and pies, or for heating up dishes before serving them.

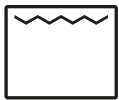

Traditional grill

This is particularly useful for cooking slim cuts of meat and for making toast and crostini.



Maxi Grill

Using the top heating element and the grill at the same time allows strong heat to be concentrated on the surface of the food, crisping it up more quickly.



Grill + fan

Suitable for cooking thicker cuts of meat or particularly large dishes, it is good for quickly reducing the excess humidity in food.



Top and bottom heating elements + fan

Ideal for fast, uniform cooking, this is particularly suitable for baking biscuits and cakes.



Circular and bottom heating elements + fan

It lets you cook similar dishes at the same time, arranged on shelves, up to a maximum of three levels.



Defrosting

This lets you defrost dishes gently, without any detrimental effect.



Eco

This allows different types of dishes to be cooked with lower consumption of electricity.



Automatic cooking programs

60 cm Touch Screen and Touch Control ovens offer a set of 16 automatic programs, with the option of setting the weight and an indication of the level at which to place the food.

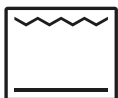

Grill + bottom heating element

The simultaneous use of the grill and bottom heating element lets you cook and brown foods at the same time.



Steam

The steam function, adjustable by degrees, permits healthy cooking of food, preserving their sensory characteristics and nutritional properties.



Steam + hot air

The combined action of steam and hot air is perfect for reheating dishes before serving them.

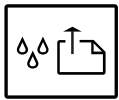

Sous vide steam

Ideal for cooking vacuum packed (in the relevant bags) food, especially animal proteins that require a specific temperature.

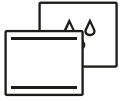

Combi-steam + top and bottom heating elements

The addition of steam to the traditional setting of the conventional oven allows you to achieve more succulent dishes.

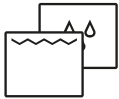

Combi-steam + grill

The combination of grill and steam allows you to have crisp, golden food without running the risk of drying or burning it.

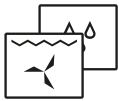

Combi-steam + grill + fan

Particularly suitable for cooking large dishes, it allows the necessary humidity to be retained throughout the cooking process.

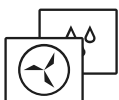

Combi-steam + circular heating element + fan

This guarantees rapid, uniform cooking of dishes that are similar to each other and arranged on different shelves, retaining the right level of humidity.



Slow cooking

Ideal for dishes, especially meat-based ones, that need long cooking at a low temperature.



Circular heating element + fan



It lets you cook similar dishes at the same time, arranged on shelves, up to a maximum of three levels.



Related Accessories



1PPI



1PPZ



1CFFA

Related Products



1FEVEPN



1FEVSP



1FEVGP



1FEVEMCN



1FEVSMC