



75 cm Icon X Exclusive built-in oven

Multiprogram

1FIXEPN

Description



- 9 manual functions
- maximum temperature: 250 °C
- capacity: 89 litres
- electronic digital start/stop
- cooking programmer and timer
- features: front controls, knobs and
- handle in Soft-Touch finish, Easy
- Clean oven lining, extractable and
- removable door with triple
- heat-reflecting glass, Soft-Close
- hinges, tangential cooling fan,
- 2 rear lights, side racks
- equipment: 1 Easy Clean enamelled
- steel drip tray, 1 steel rack, 1 pair of
- telescopic oven rails, rotisserie
- safety devices: safety
- switch-off
- maximum absorbed power: 3.5 kW

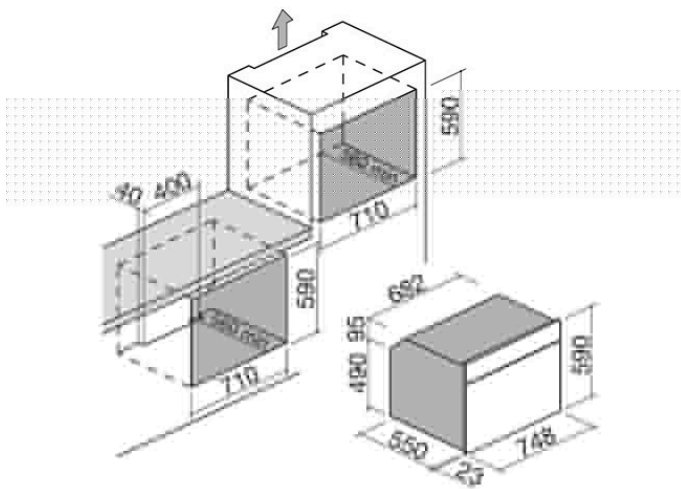

SEE OTHER AVAILABLE DESIGNS:



1FIXSP



1FIXGP



Plus

Detailed Features

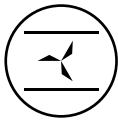

Convection functions

Multifunction electric oven with fan-assisted air circulation, distributing heat evenly for fast and uniform cooking.



Energy rating A

All 60 and 90 cm ovens by Barazza belong to energy class A: maximum efficiency to optimise performance and reduce energy consumption. Barazza operates according to an eco-sustainability principle, favouring future generations.



Soft-Touch finish elements

Elegant to the eye and pleasant to the touch, the Soft-Touch finish features on various product lines, covering knobs, handles and control panels.



Easy Clean oven interior

All Barazza ovens feature an Easy Clean interior, a surface treatment that facilitates and speeds up cleaning.

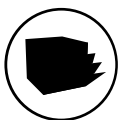

Soft-Close hinges

Soft-Close hinges are a mechanical device that slows down and cushions the final stage of door closing.



Cool door

Barazza oven doors, removable and dismountable, feature triple or quadruple glass with heat-reflective crystals that prevent the outer surface from overheating.



89-litre oven capacity

The large oven cavities help optimise cooking times, resulting in energy savings.

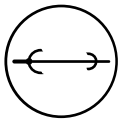

Rotisserie

When the rotisserie is inserted into the oven and a compatible cooking function is selected, it is automatically activated to rotate.



Module width 75

The ovens and coordinated products are available in three width sizes: 60, 75 and 90 cm, to adapt perfectly to every space and design requirement.



Functions

Main Functions



Top + bottom heating element

Suitable for any type of dish, but particularly effective for baking cakes, pizzas and soufflés, and for roasting.



Bottom heating element

Suitable for baking biscuits, tarts and pies, or for heating up dishes before serving them.

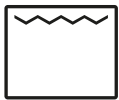

Traditional grill

This is particularly useful for cooking slim cuts of meat and for making toast and crostini.



Maxi Grill

Using the top heating element and the grill at the same time allows strong heat to be concentrated on the surface of the food, crisping it up more quickly.



Grill + fan

Suitable for cooking thicker cuts of meat or particularly large dishes, it is good for quickly reducing the excess humidity in food.



Top and bottom heating elements + fan

Ideal for fast, uniform cooking, this is particularly suitable for baking biscuits and cakes.



Circular and bottom heating elements + fan

It lets you cook similar dishes at the same time, arranged on shelves, up to a maximum of three levels.



Eco cooking

This allows different types of dishes to be cooked with lower consumption of electricity.

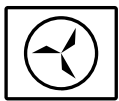

Circular heating element + fan

It lets you cook similar dishes at the same time, arranged on shelves, up to a maximum of three levels.



Installations

Installation Method

energy
rating

A

Rating A



RATING A Maximum efficiency with reduced consumption. Class A ensures high performance while fully respecting the environment and energy savings.



Related Accessories



1PPI



1PPZ



1CFFA

Related Products



1FIXSP



1FIXGP



1MOXEN



1MOXI