

## 1LLB91

**DESCRIZIONE** Lavello LAB con abbassamento incasso, filo e sottotop 86x51 - 1 vasca  
**DESCRIPTION** 86x51 cm LAB built-in, flush and undermount sink - 1 bowl with lowering

**PESO LORDO** 12.5 Kg **DIMENSIONI IMBALLO** 950x610x310 mm  
**GROSS WEIGHT** **PACKAGING DIMENSIONS**

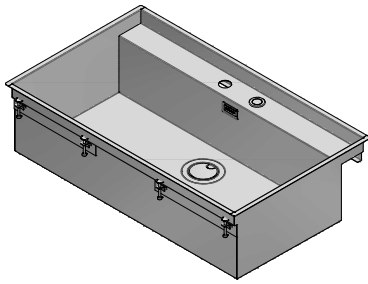

- Vasca Raggio "0" (Bowl with radius "0")
- Acciaio Inox AISI 304 di spessore elevato (AISI 304 Extra thick stainless steel)
- Dimensione vasca: 83x38.8x18.3 h (Bowl dimension: 83x38.8x18.3 h)
- Vasca con abbassamento per scorrimento accessori (Bowl with lowering for sliding accessories)
- Dotazioni pilettoni 3"1/2 (A), salterello smart, copripilettoni in acciaio inox, troppo-pieno con scarico perimetrale (Equipment: 3"1/2 basket strainer waste, smart pop-up plug, stainless steel drain cover, perimeter overflow)
- Foro rubinetto: 2 fori di serie (Mixer Tap Hole: two series hole) (B)
- Base inserimento vasca: incasso e filo 90, sottotop 100 (Base unit for bowl: built-in and flush 90, undermount 100)
- Incasso: 85x49 cm (Built-in: 85x49)
- Filotop: 86.3x51.3 cm (Flush: 86.3x51.3 cm)
- Sottotop: 82.6x47.6 cm (Undermount: 82.6x47.6 cm)

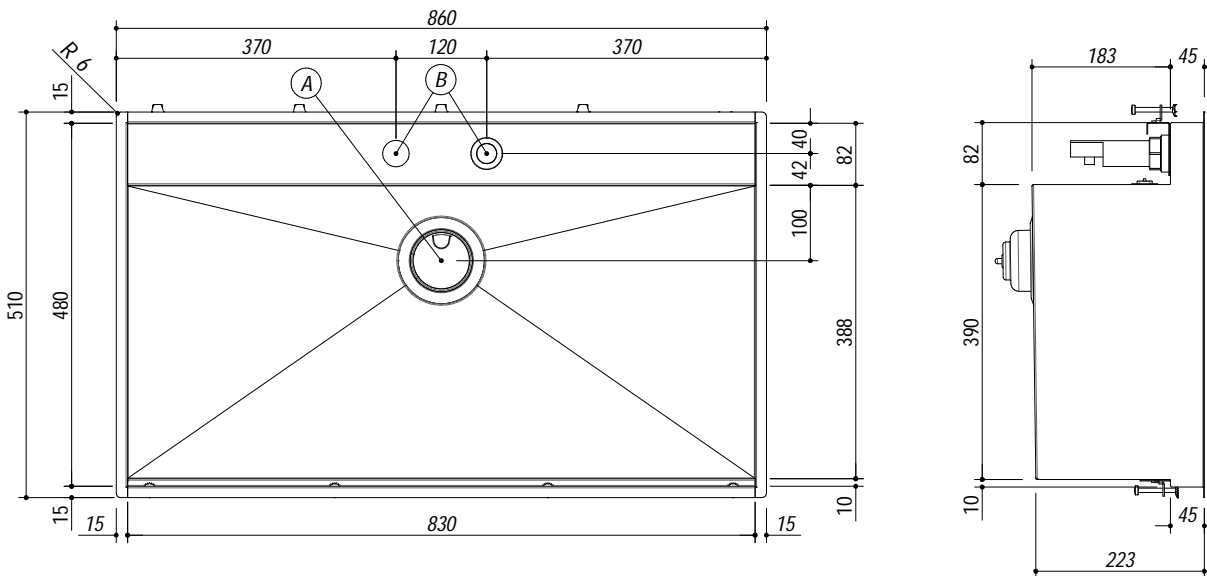

**SCALA DISEGNO** 1:10

**TUTTE LE MISURE IN mm**  
**ALL MEASURES IN mm**

**TOLLERANZA LINEARE:** ± 0.5 mm  
**LINEAR TOLERANCE**

**TOLLERANZA ANGOLARE:** ± 0.2 °  
**ANGULAR TOLERANCE**

### FORATURA PER INSTALLAZIONE SOTTOTOP UNDERMOUNT CUT-OUT FOR TOP

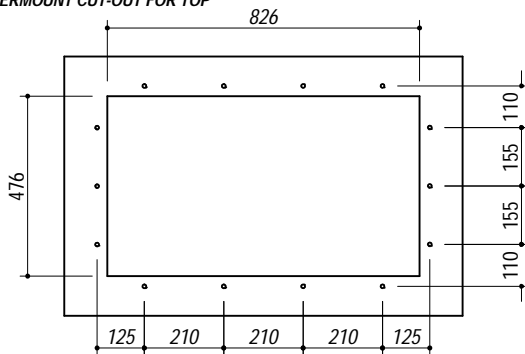

**FORO - HOLE**  
 Ø 10 X 13 H mm

**FISSAGGIO AL TOP**  
**FIXING SYSTEM**

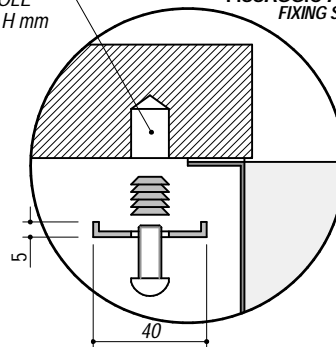

### FORATURA PER INSTALLAZIONE AD INCASSO BUILT-IN CUTOUT FOR TOP

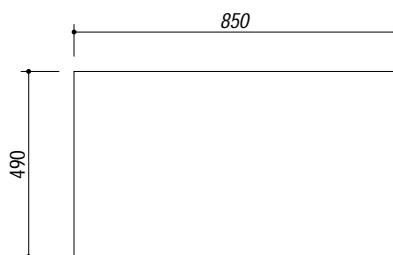

1:20

### FORATURA PER INSTALLAZIONE A FILO FLUSH CUTOUT FOR TOP

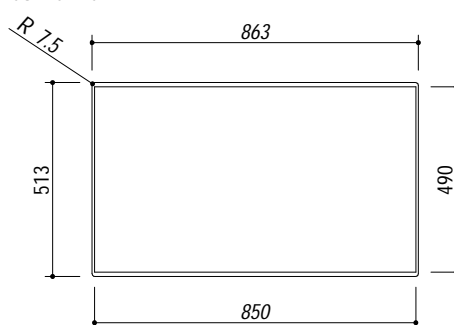

**ABBASSAMENTO**  
**LOWERING**

